

Shutter Installation Instructions

Instructions - Motor/Crank/Spring/EZ drive

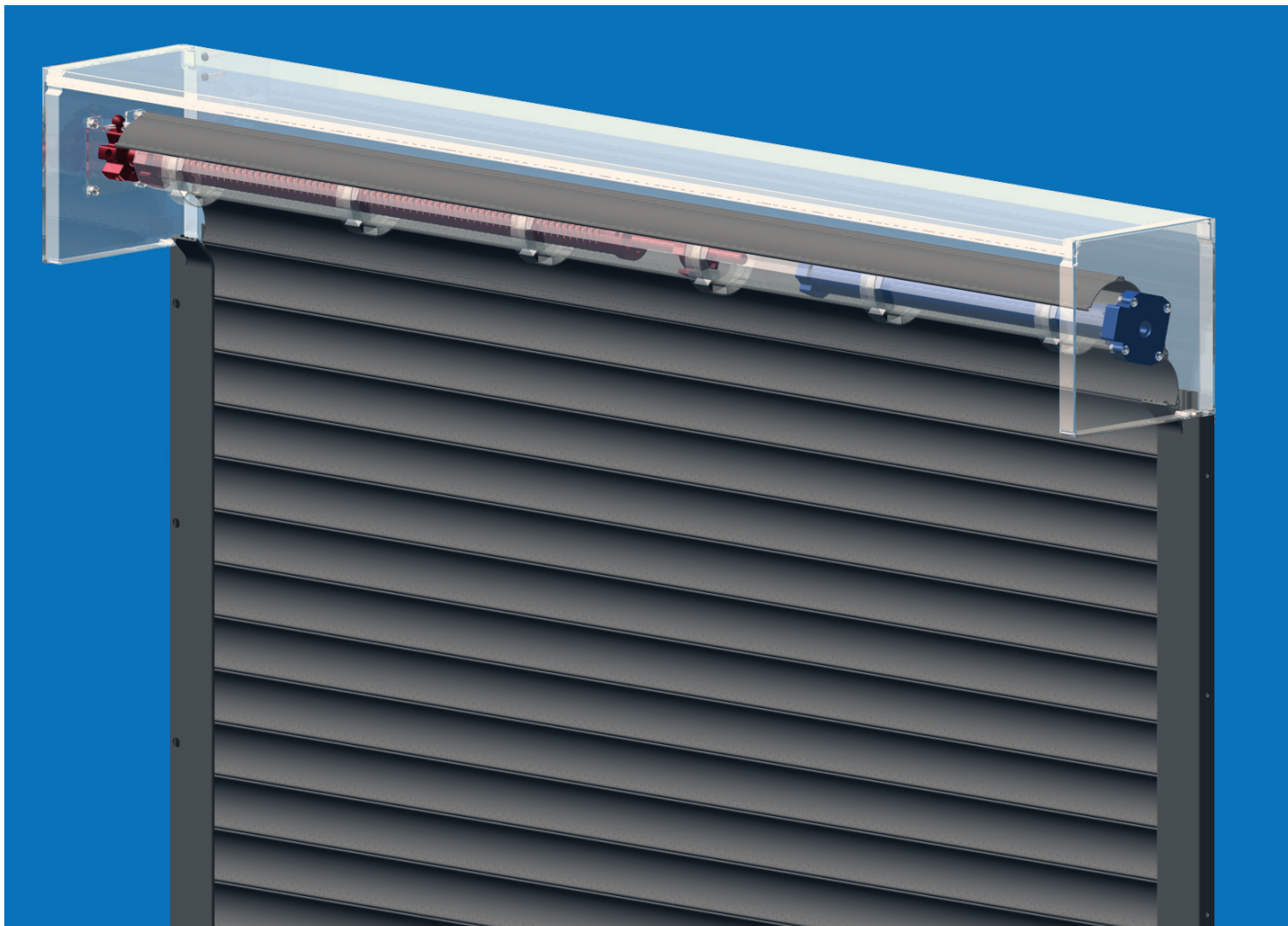

Table of Contents

Tools and materials required	2
Installation Instructions Steps 1 - 20.....	3-7
APPENDIX A - Standard 110V Motor	8-9
APPENDIX B - RTS (Radio) 110V Motor (no override)	10-12
APPENDIX C - RTS (Radio) 110V Motor (with override)	13-15
Shutter Maintenance and Operating Instructions	16

Shutter Installation Instructions

Please Note

The shutter housing must be fastened to a secure structure or the housing may fall and hurt someone.

The nipple on the end cap can break! Be especially careful not to put any undue weight or stress on the nipple during installation.

It shall be the responsibility of the installer to verify the soundness of the structure where the shutter is to be attached to ensure proper anchorage.

Build out tubes are not referenced in these instructions and may be required/desired. Dimensions at 1"x2"; 1"x3"; 2"x2"; 2"x4"; and 2"x6" hollow tubing with 1/8" and 1/4" wall thickness are available. Typically door shutters mounted to storefront will need 2"x4" tubes to clear hardware and a new parallel arm door closure may be required. Tubes may also be required for clearance issues and are available options. Proper mounting of build out tubing is subject to site conditions.

Tools Required

Drill with Magnetic Tips and Phillips Tip
Drill Bits for substrate (concrete, wood, metal)
Level
Needle Nose Pliers
Tape Measure

Material Required

Appropriate Fasteners for substrate and usage (hurricane or security)

**Follow the manufacturers wiring diagrams included in the switch or relay(s)
to complete electrical installation.**

Shutter Installation Instructions

Step 1

Remove the protective film on the top and back of the roll housing and side rails.

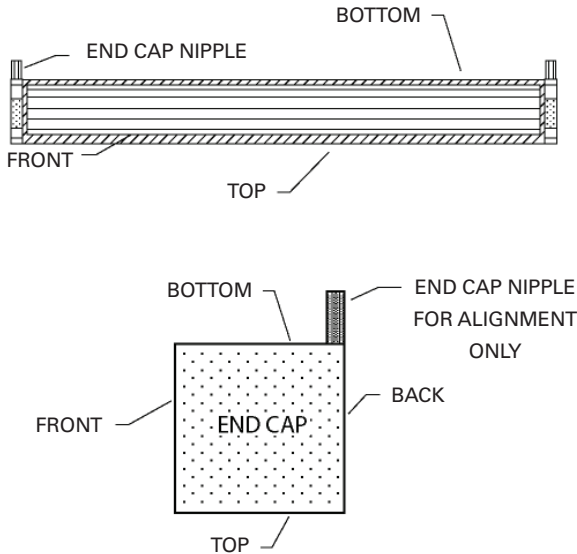

Warning: The nipple is fragile! Please DO NOT PUT any undue weight or stress on it or it will break.

Step 2

Check for RailTabs (motor rails only). Review inside bottom back corner of the end cap. Review the back side of the rail top. If your shutter has a rail tab, you will need to bend that tab outward in step #11. Do NOT bend this tab back before step #11 as the end cap nipple will not fit in the side rail after bending.

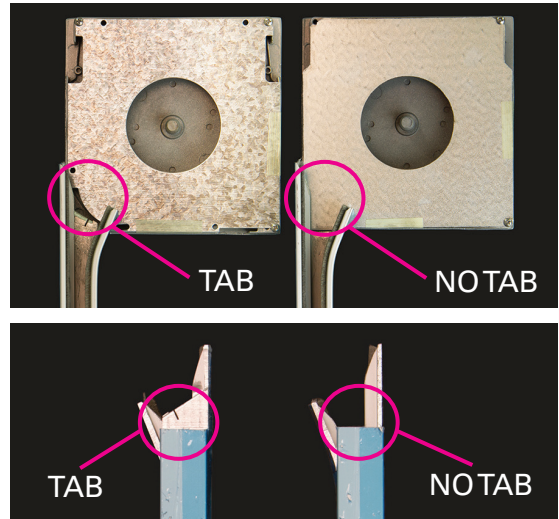

Step 3 Motor/Crank/Spring - pull/operate 10-12" of curtain out of housing.

Lay the shutter box housing on the ground. With one person holding the box housing, the second pulls/cranks/operates out 10" of curtain. Second person slides each side rail onto the end bracket nipple while guiding the curtain end retention screws into the channel in the side rails. You might need to tap the bottom of the rails to get them flush with the box. Then you may gently let go of the curtain back up to the box.

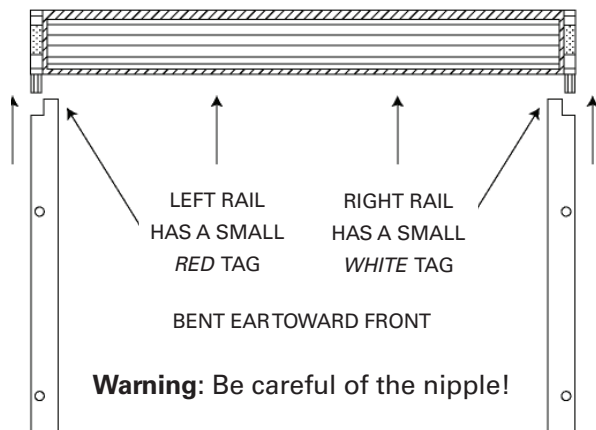

Step 4

Holding on to the box and side rails (without torquing the bracket nipple) lift the whole shutter and stand it on the side rails with the rails straight. Then lift the whole shutter up into place on your counter. *If on floor move to step #6. **If "L" angle supplied for sill, install first and then set rails onto "L" angle.

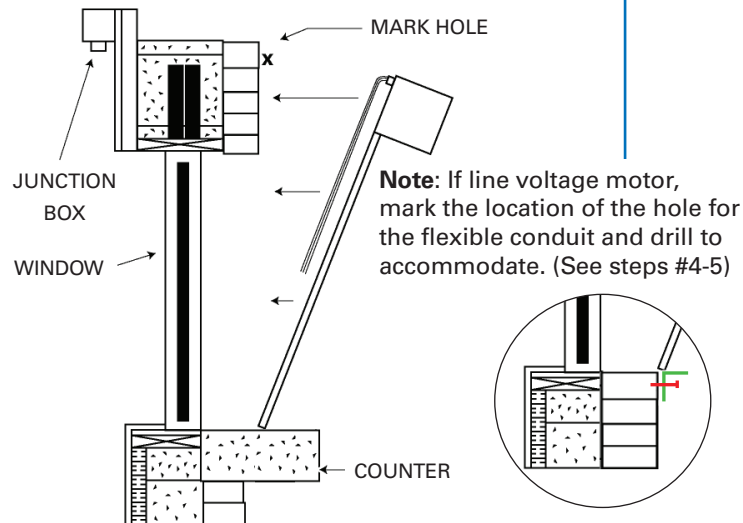

Shutter Installation Instructions

Step 5 Motor Only

Connect the flexible conduit to the connector on the shutter.

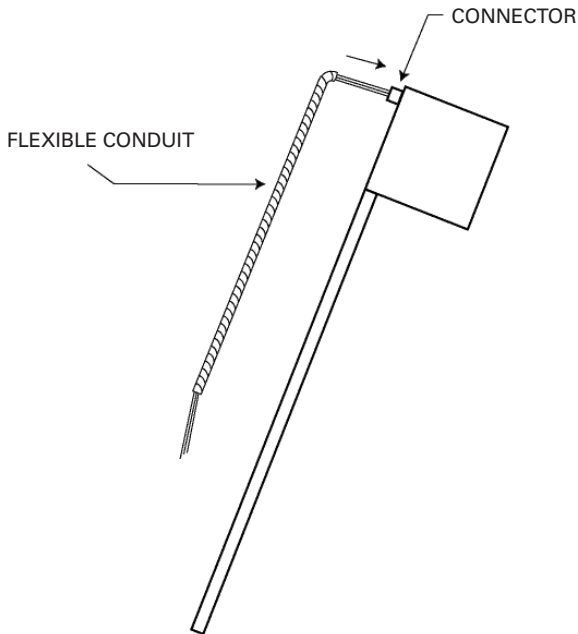

Step 6 Motor Only

Pull the flexible conduit through the wall and position the shutter in the required location.

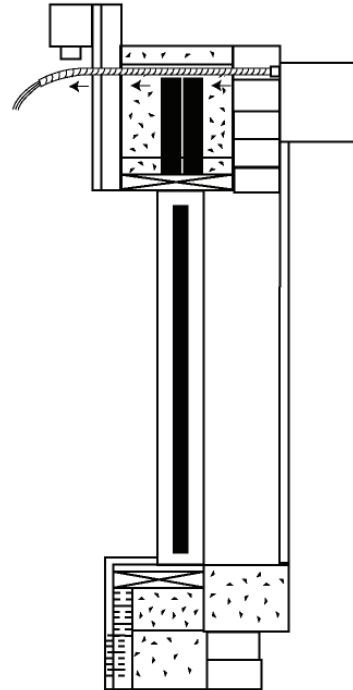

Step 7

Put one screw in top predrilled hole. (second person must keep holding the shutter against the wall until the second screw on the opposite rail is in place)

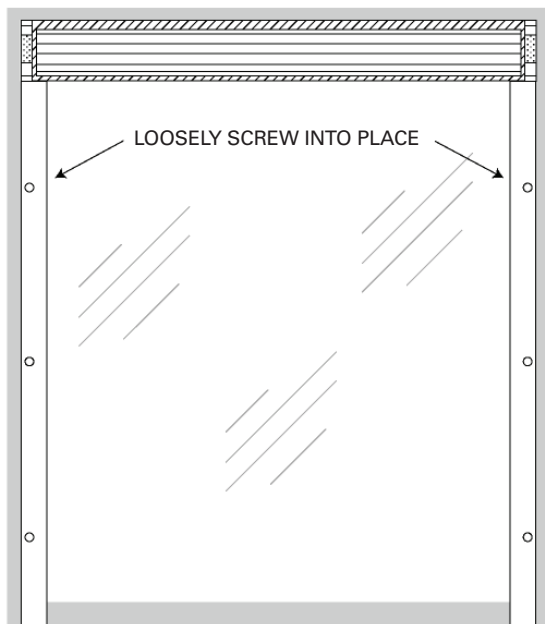

Step 8

Measure the distance of the rails at the top of the shutter. Measure the distance of the rails at the bottom of the shutter and position them to the same dimension as the top of the rails.

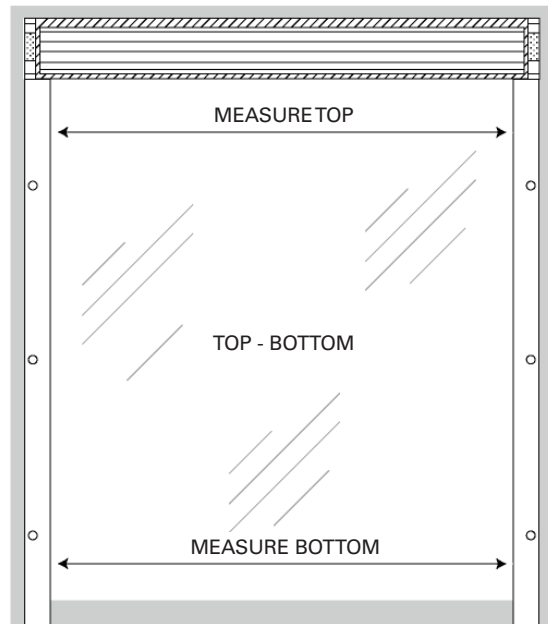

Shutter Installation Instructions

Step 9

Level and plumb the rails. Put screw into each bottom hole of the rails.

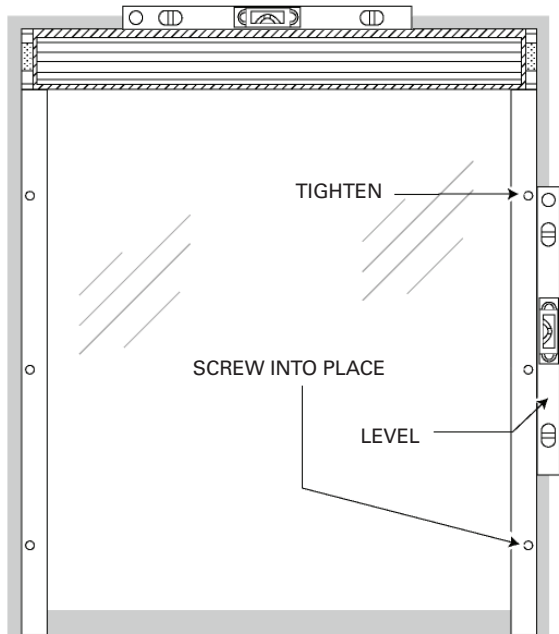

Step 10

Check the position from the top of one rail to the bottom of the opposite rail to check that the rails are totally square to each other and the shutter coil housing.

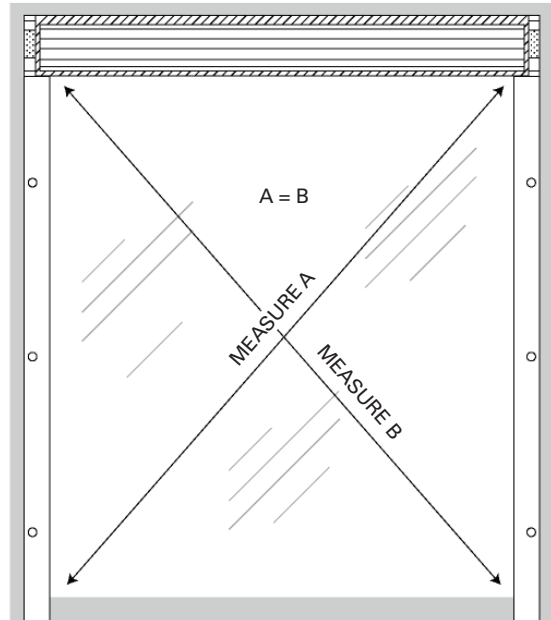

Step 11 Motor Rails Only

If determined in step #2 that rail tabs exists, then use a flat screwdriver and a hammer and bend that tab outward until flush with the end cap's galvanized safety plate. This guides the end retention screws properly into the side rail's retention channel. Not bending the tabs may result in the retention screws catching on this tab.



TAB FLUSH WITH SAFETY PLATE



TAB BENT SUCCESSFULLY

Step 12

Slowly lower the shutter to check initial alignment of the shutter curtain slats as they enter the side rails. **Note:** Do this slowly to reduce possible damage to the curtain slats.

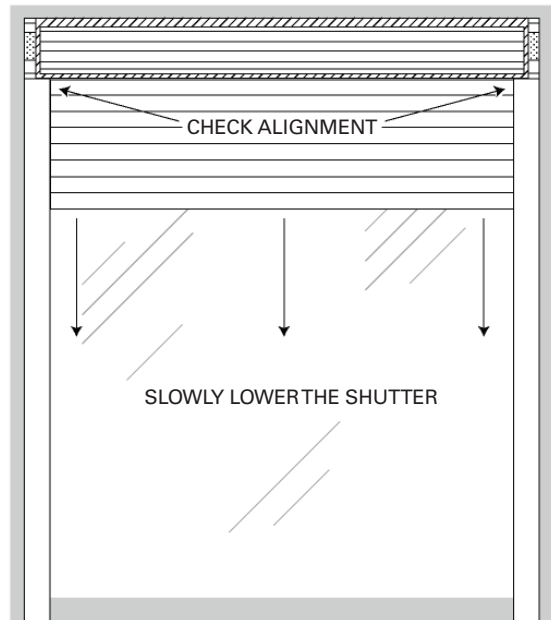

Shutter Installation Instructions

Step 13

Verify level, plumb, and square. Fasten remainder of screws.

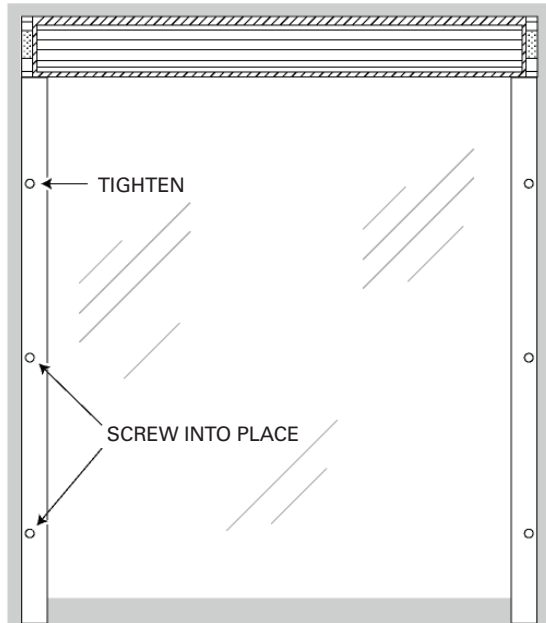

Step 14

Put decorator plug buttons in the drill holes. Or, attach snap cover to rail to hide fasteners.

Note: If EZ Drive see step #15B first.

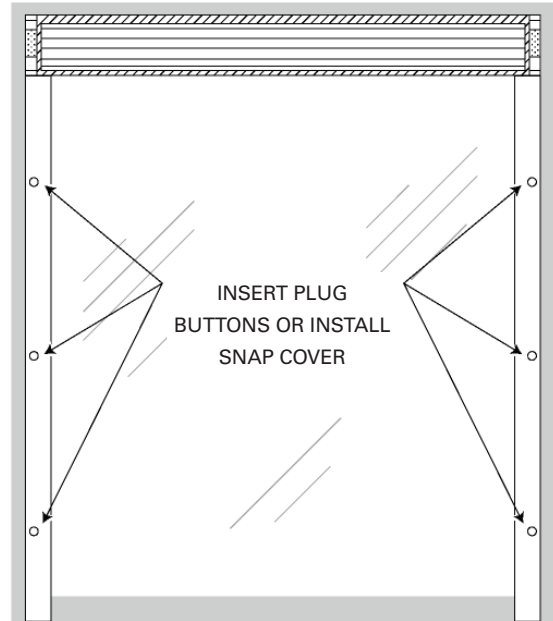

Step 15

A - B

A: Connect the flexible conduit to a junction or switch box as desired. Connect the shutter to desired control per the desired control's wiring instructions.

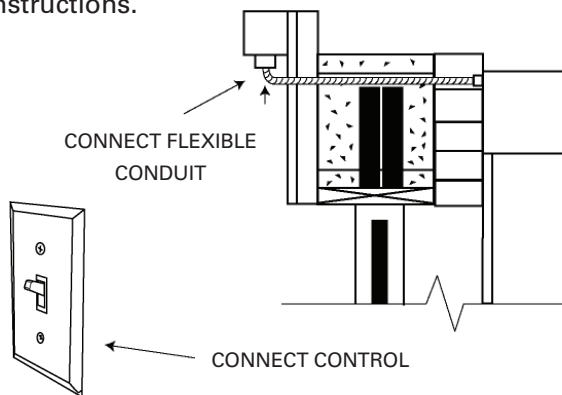

B: EZ Drive: Run the 5' low voltage motor wire down the fastener channel in the side rail. At appropriate height, drill a hole through the channel and through the building. Fish wires through hole into the building. Then apply plug on rail covers. (See instructions provided with EZ Drive for wall plate wiring)

Step 16

Remove front cover if still attached. Fasten the housing coil to the structure by putting a screw through the top/rear shutter housing above or behind the coil roll. They should be spaced no more than 18" apart.

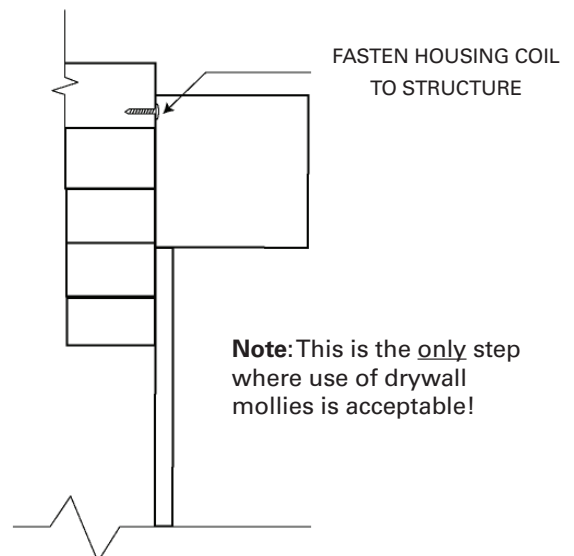

Shutter Installation Instructions

Step 17

Check operation of shutter to ensure everything is functioning properly. Verify locks work correctly. If installed on carpet, the mortise in the side rails may need to be expanded upwards with a drill bit or Dremel tool.

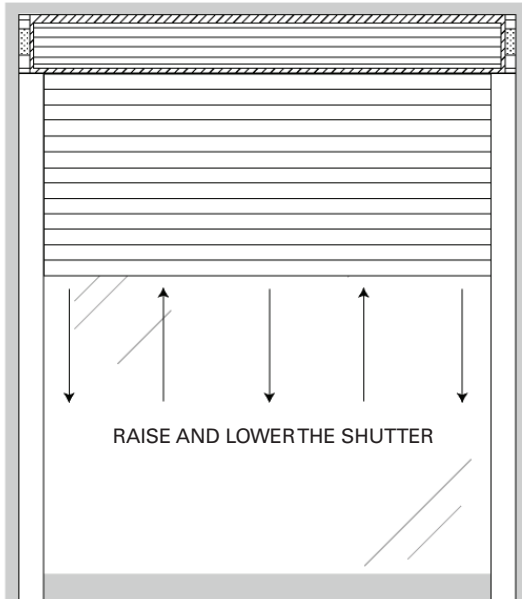

Step 18

Clean the shutter housing, rails and curtain. The inside surface of the curtain is exposed when rolled for easy cleaning.

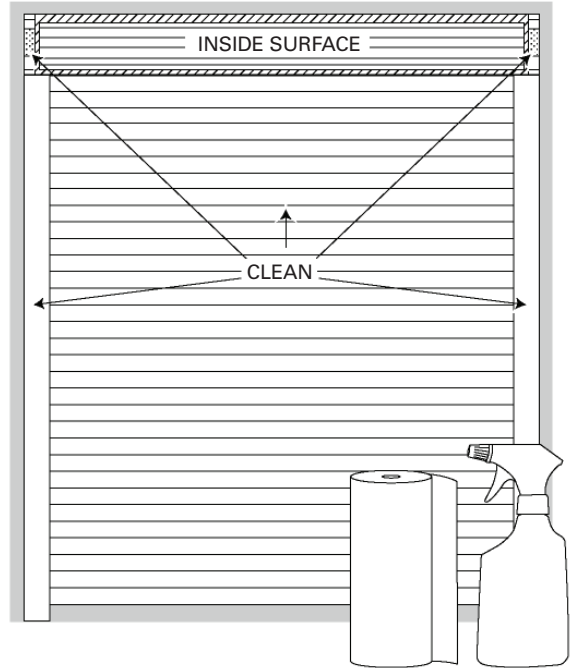

Step 19

Install the front cover of the shutter housing.

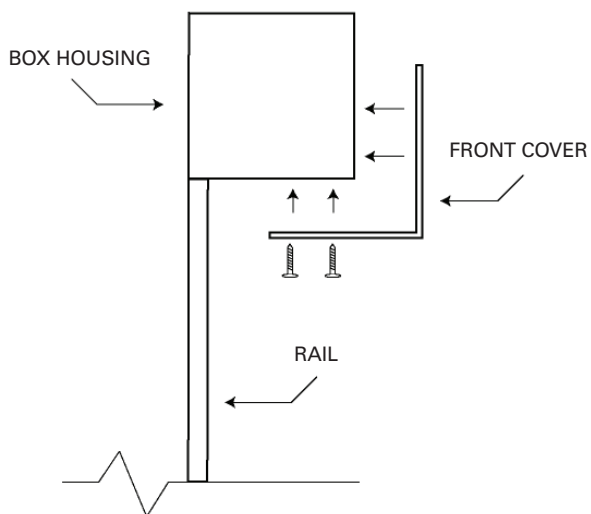

Step 20

Caulk the perimeter of the shutter for weather fastness. **Note:** For exterior applications, a top drip cap is recommended (not provided).

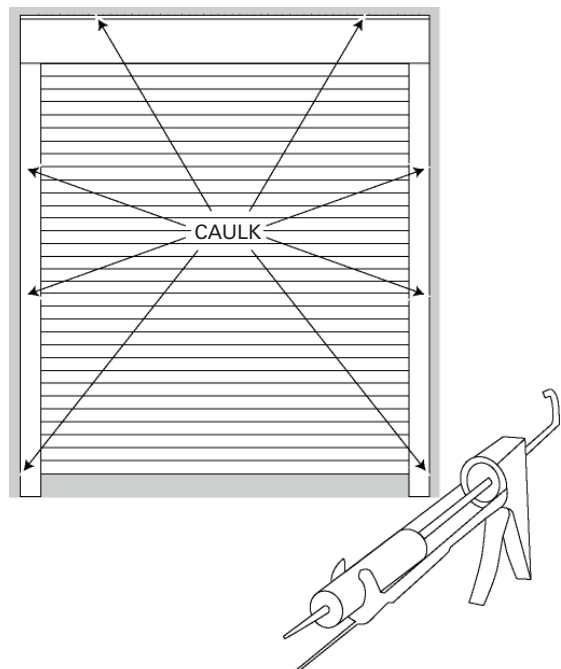

Appendix A - Standard 110V Motor



INT T3.5 - T5 - T6 - 230V - 50Hz / 120V - 60Hz

5006258G



Lire attentivement cette notice avant toute utilisation.

S.A.S. au capital de 5 000 000 € - Z.I. Les Giranaux - BP71 - 70103 Arc-Les-Gray CEDEX - RCS GRAY B 425 650 090 - SIRET 425 650 090 00011 - n° T.V.A CEE FR 87 425 650 090

Read carefully these instructions before any use.
Bitte gründlich vor der Anwendung lesen.
Deze handleiding aandachtig doorlezen alvorens het systeem te gebruiken.
Leer attentamente estas instrucciones antes de proceder a cualquier utilización.
Leer attentamente este folleto antes de cualquier utilización.
Leggere attentamente queste istruzioni prima dell'uso.

Přečtěte si pozorně návod.
Kullanmadan önce dikkatlice okuyunuz.
Διαβάστε προσεκτικά τις παρούσες οδηγίες χρήσης πριν αρχίσετε να την χρησιμοποιείτε.
Les disse instruksjonene nøye før bruk.
Læs instruktionen grundigt før brug.

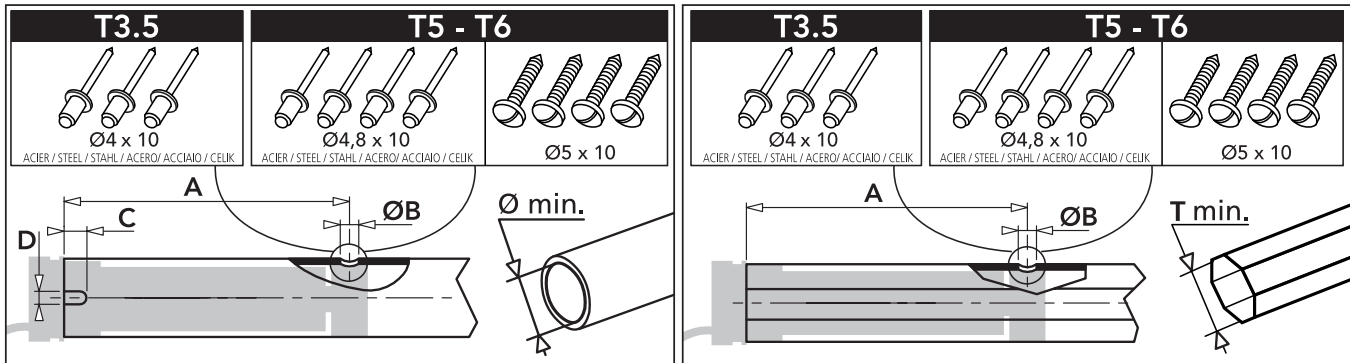
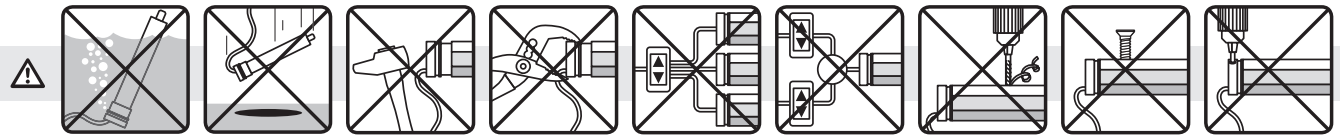

		mm				
		Ø _{min.}	A	ØB	C	D
T3.5 230V-50Hz	354-12	37	377	4,2	8	5,5
	353-25 • 356-12 • 359-12 • 3513-8		433			
T3.5 120V-60Hz	354-30 • 356-14 • 359-14	37	433	4,2	8	5,5
T5 230V-50Hz	506-12 • 506-32 • 508-17 • 510-17 • 510-12 • 515-12	47	483	5	26	4,2
	515-17		503			
	515-32 • 520-17 • 525-17 • 530-12 • 530-17 • 535-17 • 540-12 • 550-12		583			
T5 120V-60Hz	505-35	47	483	5	26	4,2
	510-12		487			
	510-35		503			
	515-18 • 520-12		583			
T6 230V-50Hz	640-17 • 655-17 • 670-17 • 685-17 • 660-12 • 680-12	60	673	5	36	8
	6100-12 • 6120-12					
T6 120V-60Hz	660-14 • 680-14 • 6100-14	60	673	5	36	8

		mm		
		T _{min.}	A	ØB
T3.5 230V-50Hz	354-12	37	377	4,2
	353-25 • 356-12 • 359-12 • 3513-8		433	
T3.5 120V-60Hz	354-30 • 356-14 • 359-14	37	433	4,2
T5 230V-50Hz	506-12 • 506-32 • 508-17 • 510-17 • 510-12 • 515-12	47	483	5
	515-17		503	
	515-32 • 520-17 • 525-17 • 530-12 • 530-17 • 535-17 • 540-12 • 550-12		583	
T5 120V-60Hz	505-35	47	483	5
	510-12		487	
	510-35		503	
	515-18 • 520-12		583	
T6 230V-50Hz	640-17 • 655-17 • 670-17 • 685-17 • 660-12 • 680-12	60	673	5
	6100-12 • 6120-12			
T6 120V-60Hz	660-14 • 680-14 • 6100-14	60	673	5

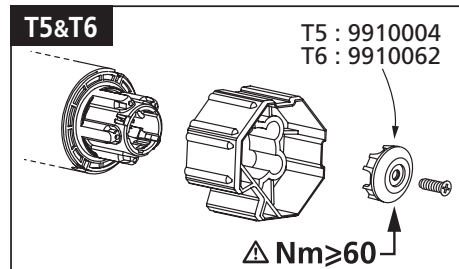
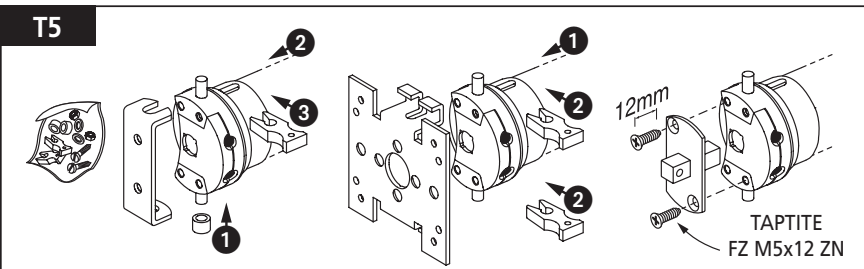
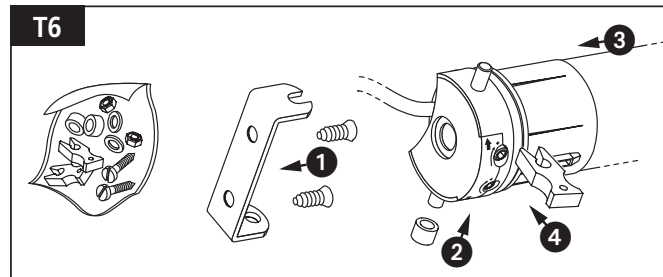
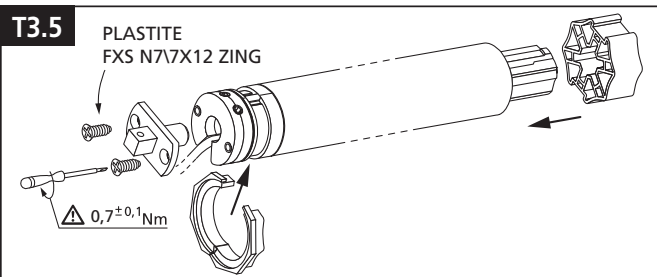

Appendix A - Standard 110V Motor

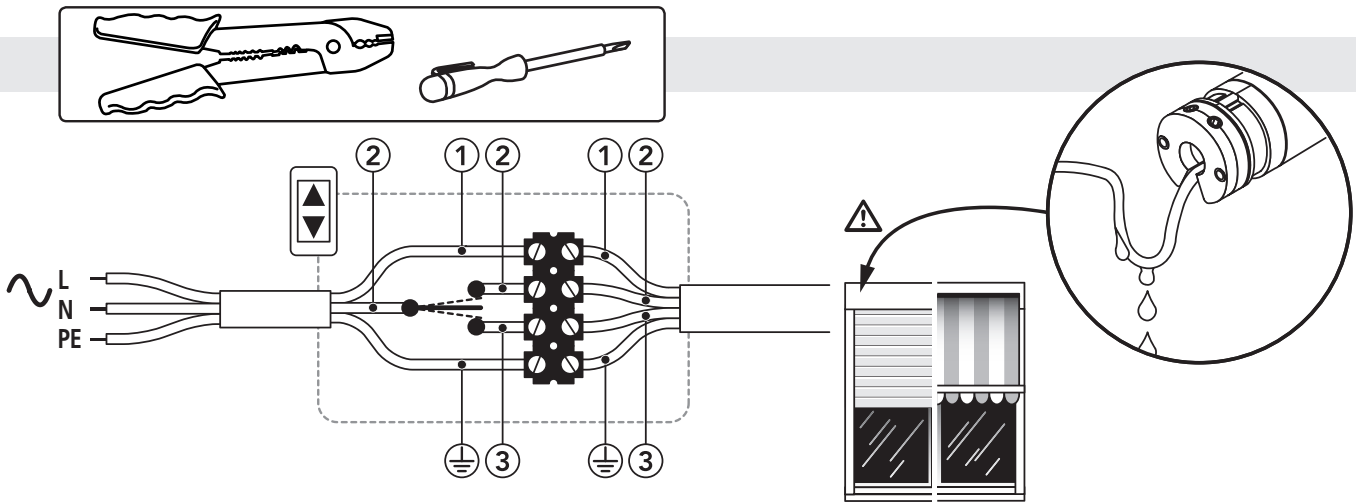

⊕	FR	GB	DE	NL	ES (230V-50Hz)	PT (230V-50Hz)	PL	CZ	DK	FI	⊕
	vert / jaune	green / yellow	grün / gelb	groen / geel	verde / amarillo	verde / amarelo	żółto/zielony	žlutozelený	grøn / gul	vihreä-keltainen	
①	bleu	blue	blau	blauw	azul	azul	niebieski	modrý	blå	sininen	①
②	marron	brown	braun	bruin	marrón	castanho	brązowy	hnědý	brun	ruskea	②
③	noir	black	schwarz	zwart	negro	preto	czarny	černý	sort	musta	③
	USA (120V-60Hz)	IT	SE	NO	ES (120V-60Hz)	PT (120V-60Hz)	GR	TR			
⊕	green	verde / giallo	grön / gul	grønn / gul	verde	verde	πράσινο / κίτρινο	yeşil / sarı			⊕
①	white	azzurro	blå	blå	blanco	branco	μπλε	mavi			①
②	black	marrone	brun	brun	negro	preto	καφέ	kestane rengi			②
③	brown	nero	swart	sort	rojo	vermelho	μαύρο	siyah			③

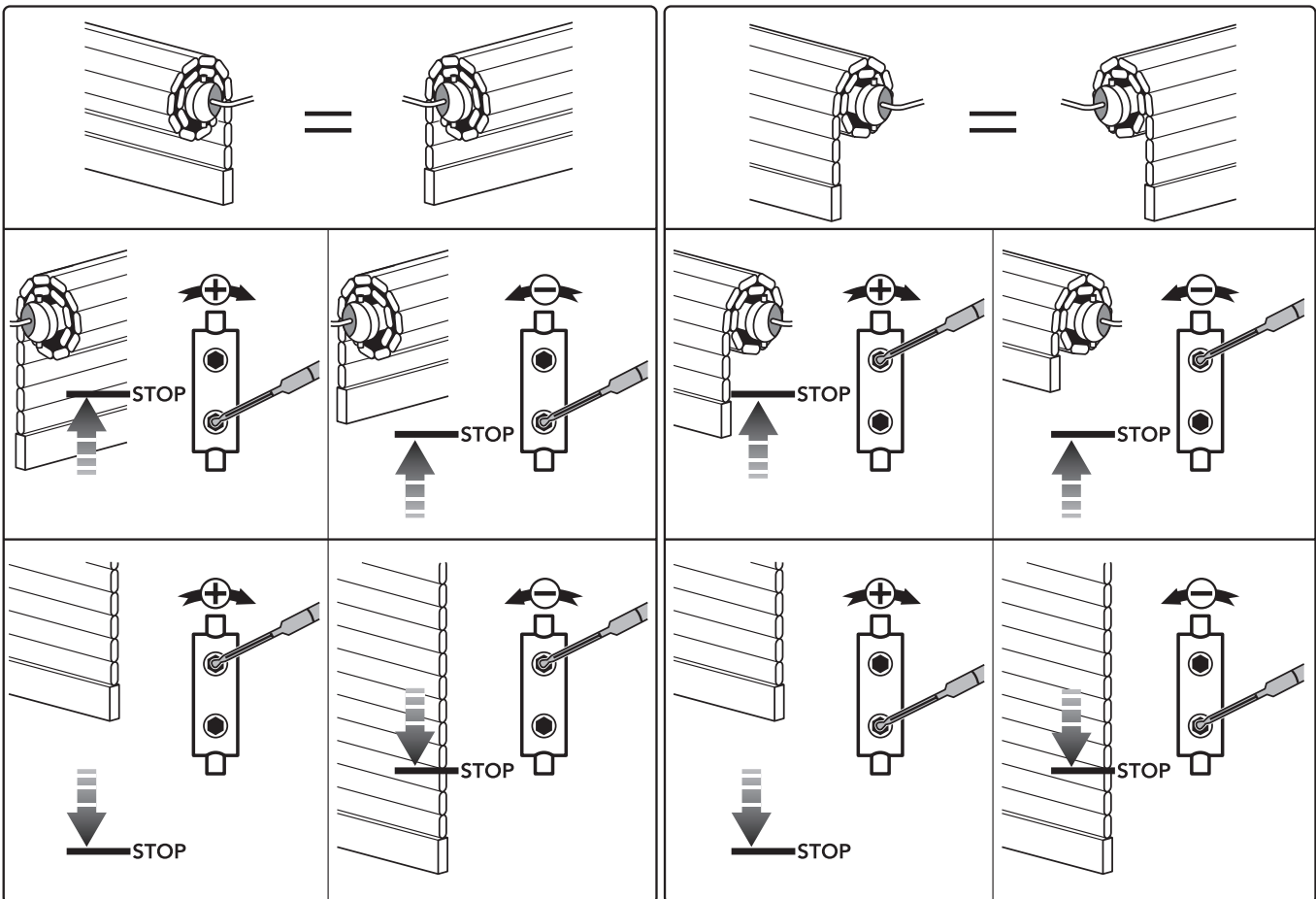

Appendix B - RTS (Radio) 110V Motor (no override)

2 WIRING

2.1 - Hz.02+ PERMANENT WIRING (shutter, shade or awning)

Warning: All wiring must conform to the National Electric Code and local codes.

- (1) The motor must be installed with a drip loop to prevent water intrusion.
- (2) Connect the motor to power using a listed junction box with appropriate cable strain reliefs.
- It is recommended a method of power disconnect for each motor be placed within sight of the motor to cut power during servicing and facilitate reprogramming.
- Do not use the motor cable to penetrate building walls. Connect the motor to power in a listed junction box and from the listed junction box run power in the manner proscribed by NEC. and local codes.

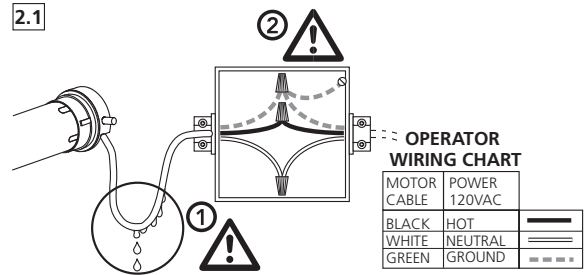

2.2 - Hz.02+ PLUG-IN WIRING (shade or awning)

Warning: All wiring must conform to the National Electric Code and local codes.

- (1) The motor must be installed with a drip loop to prevent water intrusion.
- (2) If used outdoors, a GFCI receptacle with an outdoor cover is required.
- Do not use the motor cable to penetrate building walls.

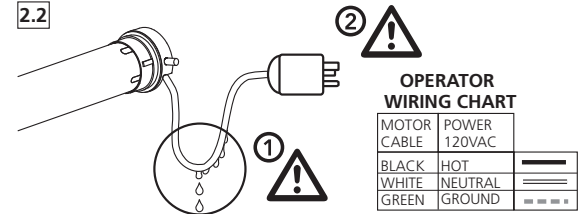

3 COMPATIBLE TRANSMITTERS

Wall switch Transmitter

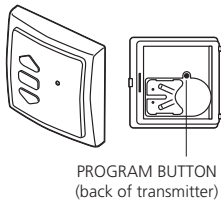

Hand Held Transmitter

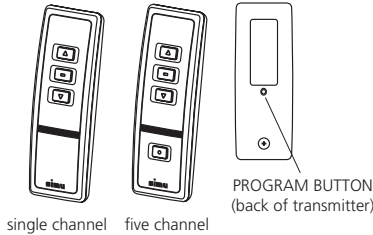

Decorator Wall Switch

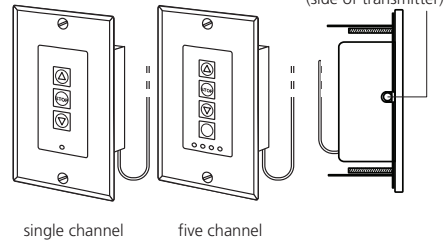

Hz Timer

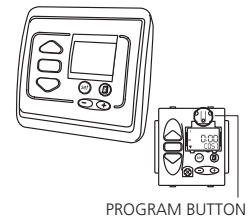

4 PROGRAMMING AND SETTING LIMITS

NOTE: The motor will jog up / down after every programming command to confirm it accepts the command.

4.1 - Power only the motor you wish to program and wake the motor up by simultaneously pressing the UP and DOWN buttons until the motor jogs.

4.2 - Press UP or DOWN button to check the direction of rotation. If wrong, press and hold the STOP button for 3+ seconds until the motor jogs. You must change the direction of rotation (if needed) at this point.

After step 4.3 you can only change the direction of rotation by returning to factory mode.

4.3 - Run the motor to the exact desired location for the **top limit** using the UP and DOWN buttons. Press the STOP and DOWN buttons simultaneously until the motor starts to run and then release them. Stop the motor at the desired **bottom limit**.

4.4 - Use the UP or DOWN buttons to position the motor at the exact desired **bottom limit** and press the STOP and UP simultaneously until the motor starts to run. Press STOP to stop the motor. You can change the limits by repeating step 4.3 for the up and 4.4 for the down limit. After step 4.5 you can only change the limits by following the process in section 7.

4.5 - With the motor stopped, press and hold the stop button until the motor jogs. This confirms the limits set in 4.3 and 4.4.

4.6 - Press the programming button on the transmitter. The motor will jog. You are now in "User Mode". The UP or DOWN button no longer has to be held for the motor to continue running.

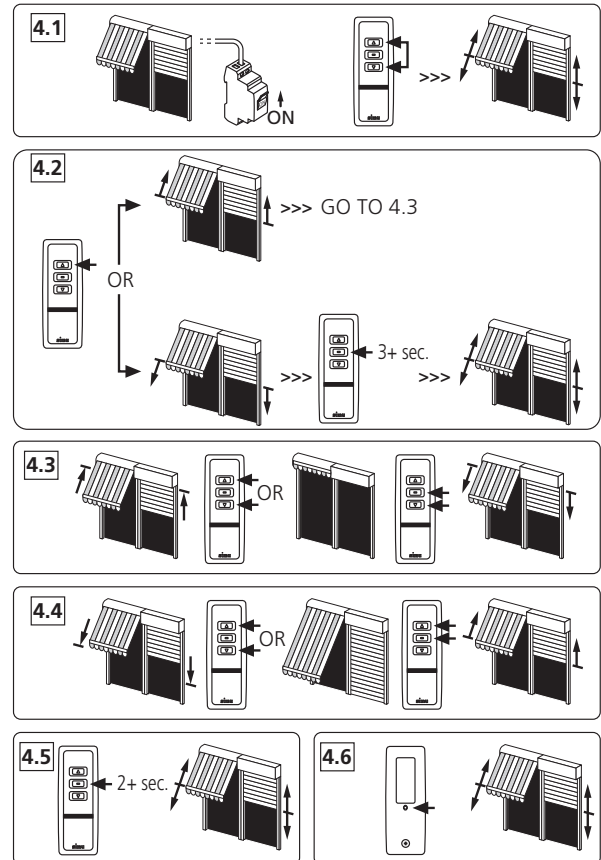

Appendix B - RTS (Radio) 110V Motor (no override)

5 ADD OR DELETE ADDITIONAL TRANSMITTERS

5.1 - To add a transmitter channel to a motor - only the motor you are working on should be powered. The motor should already be programmed to the first transmitter as per steps 4.1 through 4.6.

- a** - Start with the transmitter that already controls the motor and if it is a multi-channel transmitter, confirm it is on the channel that controls the motor. Press and hold the programming button for 3+ seconds until the motor jogs.
- b** - On the transmitter you want to add, confirm it is on the channel you wish to add and press the programming button. The motor will jog. Repeat steps **a** and **b** for every transmitter you wish to add.

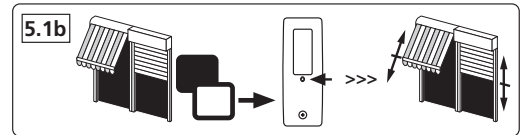
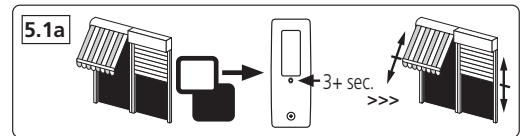

5.2 - To delete a transmitter channel from a motor - only the motor you are working on should be powered. The motor must have 2 or more channels programmed to it.

- a** - Start with the transmitter you wish to keep and if it is a multi-channel transmitter, confirm it is on the channel that controls the motor. Press and hold the programming button for 3+ seconds until the motor jogs.
- b** - On the transmitter you want to delete, confirm it is on the channel you wish to delete and press the programming button. The motor will jog. Repeat steps **a** and **b** to delete additional transmitters.

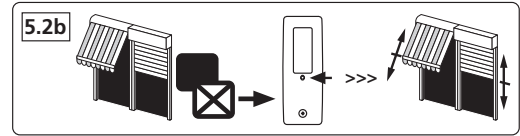
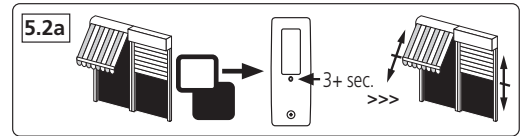

6 INTERMEDIATE LIMITS

6.1 - To set an intermediate limit, run the motor to the desired position and stop it. Then press and hold the STOP button for 5 seconds until the motor jogs.

6.2 - To run the motor to the intermediate limit, start with the motor stopped at any position. Press the stop button and the motor will automatically run to the position set in 6.1.

6.3 - To move the intermediate limit, run the motor to the new desired position and stop it. Then press and hold the STOP button for 5 seconds until the motor jogs.

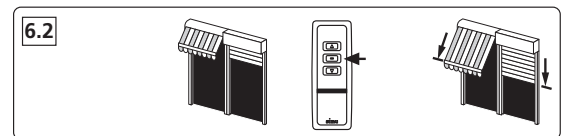
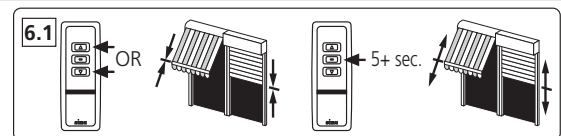

7 MOVING END LIMITS ON A PROGRAMMED MOTOR

7.1 - Use the transmitter to run the motor to the limit you wish to change (example shows UP limit).

7.2 - With the motor stopped at the current limit, press and hold the UP and DOWN buttons for 5 seconds until the motor jogs.

7.3 - Run the motor to the position desired for the new limit.

7.4 - Press and hold the STOP button for 2 seconds until the motor jogs.

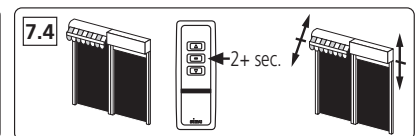
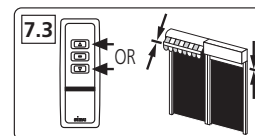
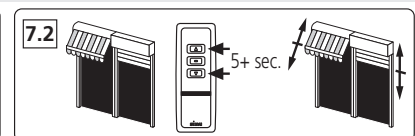
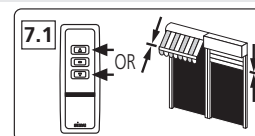

8 RESETTING THE MOTOR (double power cut)

8.1 - Start with the motor connected to power. Cut the power off for 8 seconds. Turn on the power for 8 seconds. Turn the power off for 8 seconds. Turn the power on. The motor will start running.

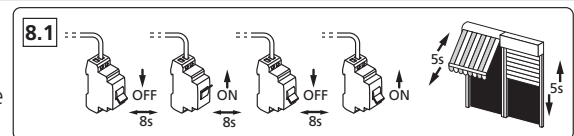

NOTE: If needed repeat the process until the motor runs.

8.2 - Press the programming button on the transmitter for 8+ seconds. The motor will jog twice.

- If the transmitter was not programmed to the motor, the transmitter will now be added to the motor and all old transmitters will be cleared from the memory.

- If the transmitter was programmed to the motor, the motor will now be back in Factory Mode. Go to section 4.1.

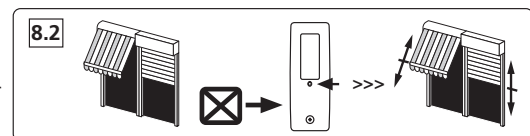

NOTE: If you wish to return a motor to Factory Mode and not have a transmitter that controls the motor follow the procedure 8.1 and 8.2 to add a transmitter and then repeat steps 8.1 and 8.2 to return the motor to Factory Mode.

Appendix C - RTS (Radio) 110V Motor (with override)

SIMU

USA

DMI5Hz - DMI6Hz MOTORS

Tubular operators with integrated radio and manual override for blinds, awnings & roller shutters

5047058A

IMPORTANT - Review instruction thoroughly before installing Hz motors

S.A.S. au capital de 5 000 000 € - Z.I. Les Giranaux - BP71 - 70103 Arc-Les-Gray CEDEX - RCS GRAY B 425 650 090 - SIRET 425 650 090 00011 - n° T.V.A CEE FR 87 425 650 090

WARNING

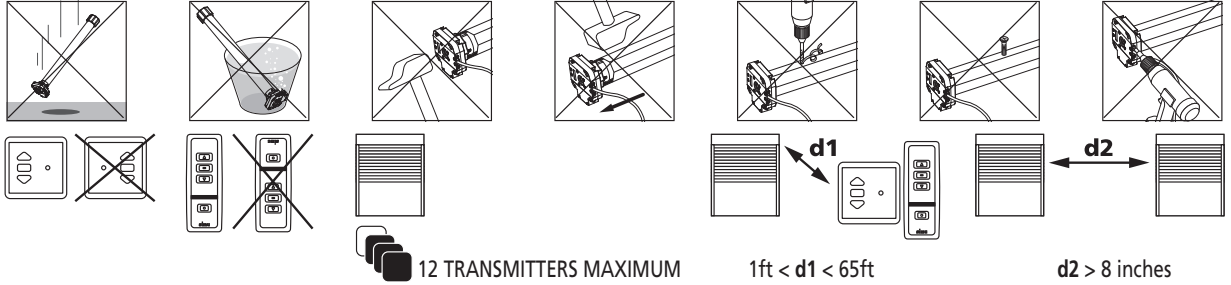

- This device complies with part 15 of the FCC Rules. Operating is subject to the following two conditions:

- (1) This device may not cause harmful interference.
- (2) This device must accept any interference received, including interference that may cause undesired operation.

- **Caution:** Changes or modifications not expressly approved by the party responsible for compliance could void the user's authority to operate the equipment.

1 ASSEMBLY

1.1 - TUBE PREPARATION

Warning: do not cut or drill the tube with the motor installed.

- Cut the tube to the required length.
- Remove all burrs from the tube.
- If using a round tube, cut a notch (D wide by C long) into one end of the tube.
- On round tubes measure length (A) and drill 4 holes around the tube. For octagonal tubes 1 hole is sufficient.

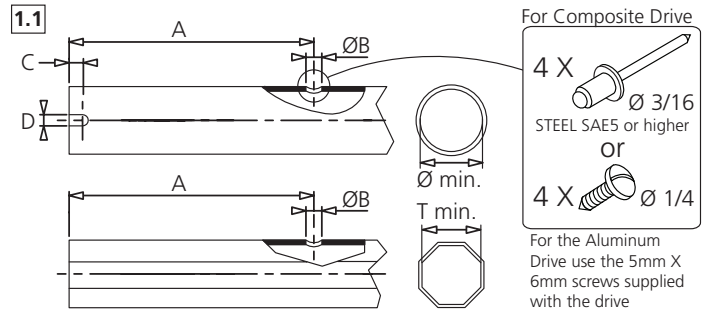

1.2 - INSTALLING THE TUBULAR MOTOR

- 1- Fit the adaptor over the crown. Align the slot in the adaptor with the raised key and firmly fit the adaptor over the crown. A crown adaptor is not necessary with 47mm (2") tubes.
- 2- Snap the drive wheel onto the drive shaft. Screw on the drive stop if needed (60 Nm+ operators).
- 3- Slide the tubular motor into the tube. Do not force or hammer on the head of the motor. If the motor does not insert smoothly, remove the motor and file smooth the edge of the tube. On round tubes confirm the raised key on the crown fits snugly into the cut slot on the end of the tube.
- 4- Secure the drive wheel to the tube. For the composite drive, use four 3/16" dia. steel pop rivets or four 1/4" dia. screws with steel grade SAE 5 or higher. For the aluminum drive, use the three 5mm X 6mm cheese head screws provided.

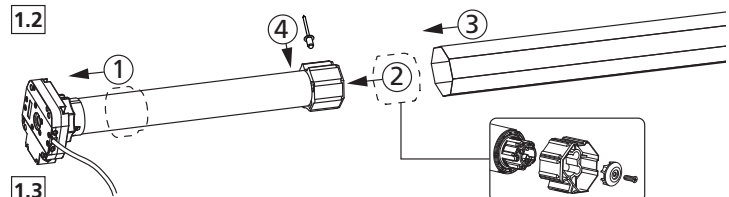

1.3 - MOUNTING THE TUBULAR MOTOR

The Hz DMI motor uses standard DMI accessories.

- Mount the motor as shown using only SIMU accessories.
- Mount the motor heads at least 8" apart from each other to prevent RF interference.
- Always install the power cable with a drip loop to prevent water penetration.
- SIMU motors conform to IP44 requirements and as such must be protected against direct weather elements such as rain, sleet, ...etc. Failure to do so could result in voiding the warranty.

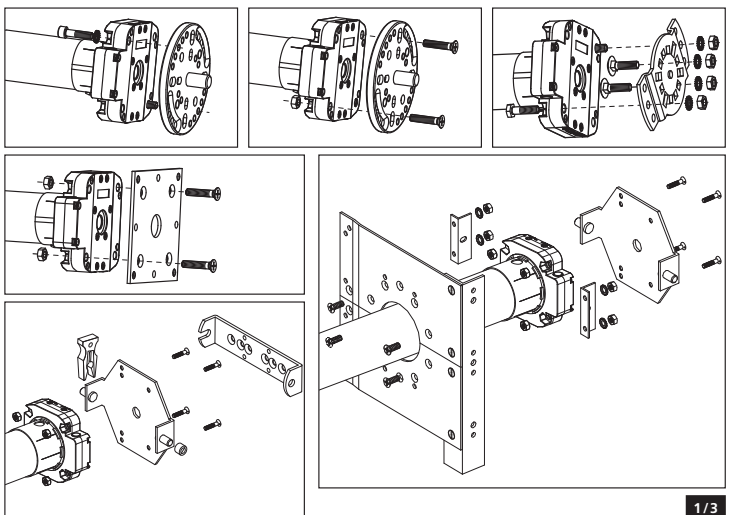

Appendix C - RTS (Radio) 110V Motor (with override)

2 WIRING

2.1 - DMI Hz PERMANENT WIRING (shutter, shade or awning)

Warning: All wiring must conform to the National Electric Code and local codes.

- (1) The motor must be installed with a drip loop to prevent water intrusion.
- (2) Connect the motor to power using a listed junction box with appropriate cable strain reliefs.
- It is recommended a method of power disconnect for each motor be placed within sight of the motor to cut power during servicing and facilitate reprogramming.
- Do not use the motor cable to penetrate building walls. Connect the motor to power in a listed junction box and from the listed junction box run power in the manner proscribed by NEC. and local codes.

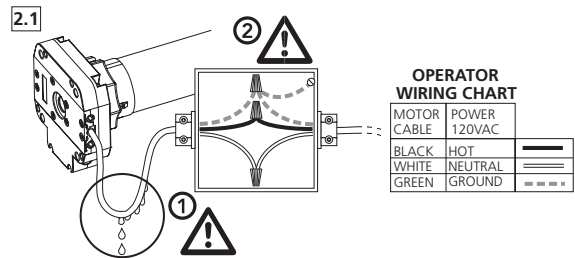

2.2 - DMI Hz PLUG-IN WIRING (shade or awning)

Warning: All wiring must conform to the National Electric Code and local codes.

- (1) The motor must be installed with a drip loop to prevent water intrusion.
- (2) If used outdoors, a GFCI receptacle with an outdoor cover is required.
- Do not use the motor cable to penetrate building walls.

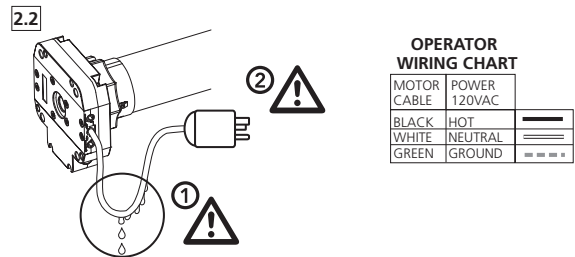

3 COMPATIBLE TRANSMITTERS

Wall switch Transmitter

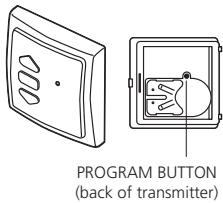

PROGRAM BUTTON (back of transmitter)

Hand Held Transmitter

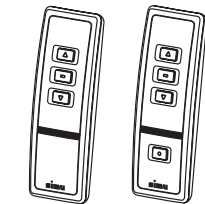

single channel five channel

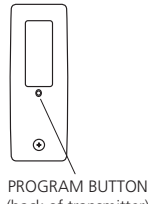

PROGRAM BUTTON (back of transmitter)

Decorator Wall Switch

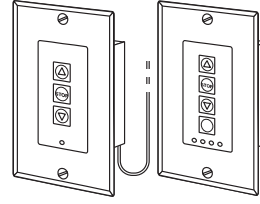

single channel five channel

PROGRAM BUTTON (side of transmitter)

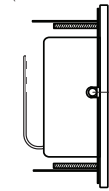

Hz Timer

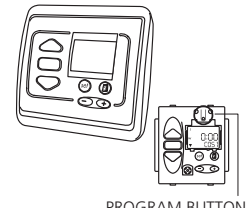

PROGRAM BUTTON

4 PROGRAMMING

4.1 - WAKING UP THE MOTOR.

Before programming, changing direction of rotation, setting the limits, etc...you must wake the motor up. If using a multi-channel transmitter, confirm you are on the desired channel. Press and hold the UP and DOWN together until the motor gives a short up/down bounce. The motor is now awake.

4.2 - DIRECTION OF ROTATION.

You must check the direction of rotation before programming. If the direction of rotation is not correct, press and hold the STOP Button until the motor gives a short up/down bounce. Confirm the direction of rotation is now correct.

4.3 - PROGRAMMING A TRANSMITTER CHANNEL TO A MOTOR.

If using a multi-channel transmitter, confirm you are on the desired channel. Press the Program Button and the motor will give a short up/down bounce. Confirm the transmitter now controls the motor. A short push on the UP or DOWN button should make the motor run until you stop it or the motor stop at its limits. You should not have to hold the button down.

4.4 - ADDING ADDITIONAL TRANSMITTERS (CHANNELS) TO THE MOTOR.

Use the transmitter that currently controls the motor and confirm it is on the correct channel. Press and hold the Program Button until the motor gives a short up/down bounce. Confirm transmitter is on the channel you wish to add and press the Program Button. The motor will give a short up/down bounce. The new channel is now added. Repeat for any additional transmitter channels you wish to add.

4.5 - DELETING A TRANSMITTER CHANNEL TO A MOTOR.

Use a transmitter that currently controls the motor and confirm it is on the correct channel to control the motor. Press and hold the Program Button until the motor gives a short up/down bounce. Press the Program Button of the second transmitter until the motor gives a short up/down bounce. The second transmitter is now deleted.

4.6 - CLEARING THE MEMORY OF OLD TRANSMITTERS AND ADDING NEW TRANSMITTERS.

If all a motor transmitters are lost or damaged it is possible to clear the old memorized codes from memory and add the new transmitter. Perform a double power cut in the following sequence:

1- Power off for at least 8 seconds

2- Power on for 8 seconds

3- Power off for at least 8 seconds

4- Power on. The motor will try and run for 5 seconds but will not run past its limits.

The motor is now in a temporary mode for 2 minutes. **NOTE: this is not the "factory mode"**. Press and hold the Program Button of any unmemorized transmitter for more than 8 seconds. When the motor gives a short up/down bounce release the button. The memory of the motor's receiver is now cleared of the old transmitters and the new transmitter has been added. If a motor or motors are entered into temporary programming mode by mistake it can be cancelled by pressing for a second on the UP, STOP or DOWN of any transmitter that motor has memorized. The motor will also return to normal operating mode if left for 2 minutes.

Appendix C - RTS (Radio) 110V Motor (with override)

4.7 - RETURNING TO ORIGINAL FACTORY MODE (deleting all transmitters).

NOTE: When the motor is in factory mode is the only time the direction of rotation can be changed. To return the motor to Factory Mode, perform a double power cut as described in section 4.6. Press and hold for 8 seconds the Program Button of an **already recorded transmitter**. The motor will give a short up/down bounce. Release the Program Button. The motor is now in factory mode. To wake the motor up press UP & DOWN until the motor gives a short up/down bounce. All transmitters are cleared from memory, the control will be in a momentary fashion (motor will move only as long as the transmitter button is held down).

NOTE: If you did not use a transmitter that was memorized by the motor, you will have to repeat the process a second time.

4.8 - TROUBLESHOOTING.

- Motor goes up when down is pressed: go to step 4.2 "setting direction of rotation".
- Can not change the Direction of Rotation: Confirm the motor is in "Factory Mode" (it only runs as long as the transmitter button is held down). If it is not, go to step 4.7
- Lost transmitter: Go to step 4.6 to clear old transmitters from memory and add new transmitter.
- The motor will not react to any transmitter: Confirm the motor has power to it. Make sure the motor is awake by pressing UP and DOWN together until the motor gives a short up/down bounce. If it does not work, cut power for 3 seconds and try again. If the motor still will not react to the transmitter, follow the instructions in step 4.6.
- The motor stops responding to the transmitter after a power loss: The motor was still in factory mode. Follow steps 4.1, 4.2 and 4.3 above. If the Program Button is not pressed as in step 4.3, the motor is not programmed.
- The motor only runs as long as the transmitter button is held down: The motor has not been programmed. Go to step 4.2 and 4.3 above.

5 SETTING THE LIMITS

LIMIT ADJUSTMENT SCREWS ON OPPOSITE SIDE FROM MOTOR CABLE

1 MATERIAL ROLLS DOWN ON SAME SIDE AS LIMITS

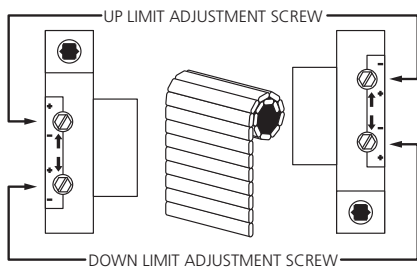

2 MATERIAL ROLLS DOWN ON OPPOSITE SIDE AS LIMITS

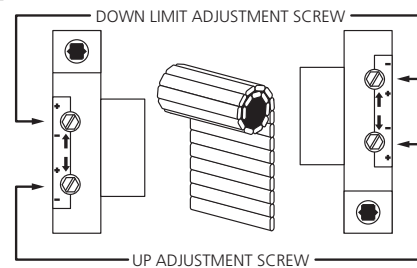

LIMIT ADJUSTMENT SCREWS ON SAME SIDE FROM MOTOR CABLE

3 MATERIAL ROLLS DOWN ON SAME SIDE AS LIMITS

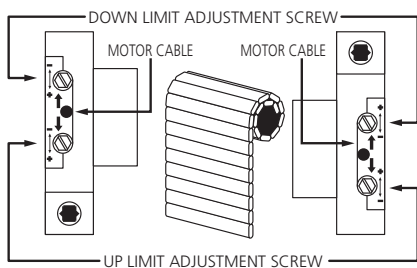

4 MATERIAL ROLLS DOWN ON OPPOSITE SIDE AS LIMITS

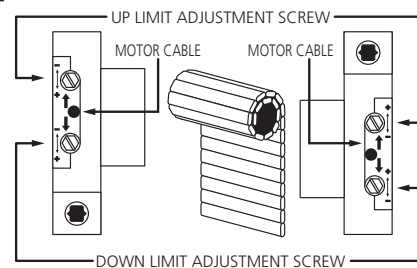

- 5.1 - Identify which limit adjustment screw controls the up limit and which controls the down limit (see above diagrams). It is important to note that the arrows by the limits adjustments screws refer to the tube's rotation. Thus if the material comes off the tube on the back side and you are adjusting the limits from the side that the motor cable is not on (as per diagrams 2), the limit adjustment screw with the arrow facing up controls the down limit and vice-versa.
- 5.2 - Turning an adjustment screw positive (+) will increase the maximum travel in the direction that it controls and turning it negative (-) will decrease the maximum travel. For the adjustment screws on the side without the motor cable, turning clockwise is positive (+) and counterclockwise is negative (-). For the adjustment screws on the side with motor cable, turning clockwise is negative (-) and counterclockwise is positive (+).
- 5.3 - To set a limit, run the motor in the selected direction.
- 5.4 - If the motor stops on its own before reaching the desired stop, turn the appropriate limit screw positive (+). Every 2 or 3 turns of the limit adjustment screw will allow the motor to travel about 1 inch further. After every few turns of the limit adjustment screw use the control switch to move the motor to the new limit position. If the motor does not stop on its own before reaching the desired stop, go to step 5.6.
- 5.5 - When you are approximately at the desired stop, use the control switch to run the motor away from the limit 2 or 3 feet and then back. This will allow you to see precisely where the limit is set. Make small adjustments and repeat.
- 5.6 - If the motor does not stop on its own at least 6 inches before the desired limit position, stop the motor with the control switch. Then turn the adjustment screw in the negative (-) direction. Confirm that the motor is stopped at the limit and set the limit as in step 5.4 and 5.5. If the motor is not stopped at the limit, continue turning the limit adjustment screw (up to 120 turns may be required).

NOTE: The motor has a built-in thermal cut-off. If after several minutes of use the motor will not run in either direction allow the motor to cool approximately 20 minutes.

Shutter Installation Instructions

Shutter Maintenance and Operating Instructions

Your Rolling Shutters should be operated as often as possible to ensure optimal performance. Once per week is recommended, but a minimally accepted standard is once per month. This will shake loose any foreign substance that may accumulate on the slats and side tracks. DO NOT force your shutter to open or close.

CLEANING INTERIOR SHUTTERS: With the shutters in the completely open position, use a damp cloth or towel to wipe down the inside of the side tracks. Spray the inside of the side tracks with DRY SILICONE SPRAY ONLY. DO NOT use any oil-based lubricants such as *WD-40*. Then, dampen a cloth with the silicone spray and wipe down the outside of the box housings, the exterior of the side tracks and the entire universal and handle assembly. This procedure should be performed 2x per year.

CLEANING EXTERIOR SHUTTERS: Place the shutters in the completely closed/down position and wash slats with *Fantastic, 409*, or equivalent using a garden hose or power washer. Use a soft bristle brush on the slats and also inside the side tracks. RINSE COMPLETELY, then follow interior cleaning procedure.

COASTAL WARRANTY REQUIREMENTS: "Coastal Area" is defined as shutters installed within 2 miles of a salt water coastline.

Cleaning twice annually and operating the shutters up and down two times per month (24x per year minimum) is required to maintain the shutter warranty in Coastal Areas. If determined that the Purchaser failed to adhere to the required maintenance in the Coastal Requirements, all warranties shall be void.

If rolling shutters have been in the down position for prolonged periods, it is important to hose off the shutter BEFORE operating the shutter back up into the box housing. Sand and debris can accumulate in the slat hinges and prohibit smooth operation of your shutter. 2x annual cleaning instructions: starting at the top of the curtain, use a spray attachment on a water hose and thoroughly spray along each slat segment to ensure sand and debris are removed from the curtain area. Additionally, spray the vertical side track openings starting at the top, and working down the track opening clearing any debris buildup. Saturate the side rail felt to break down embedded salt and debris. Wash the curtain and rails with a cleaner/degreaser - such as Simple Green with a soft bristled brush. Then follow "cleaning interior" instructions.

WINTER CONDITIONS: During freezing conditions, ensure the curtain and side tracks are clear of any ice or snow buildup before raising the shutter into the box housing. Raising the shutter with frozen debris attached to the curtain or rails could cause damage to the shutter system. Additionally, use caution not to roll up a wet shutter curtain when freezing conditions may be imminent as dropping temperatures could freeze the water on the coiled curtain with ice inside the box housing. If the shutter is not operating smoothly during freezing conditions, never force the shutter up or down.



To operate gear and crank shutters:

To Raise: Stand away from the wall holding the crank handle at a 45° angle, bend the handle at the two elbows and turn the handle until the shutter is in the desired position. DO NOT attempt to roll the curtain all the way into the box housing - 2-3" of slat MUST stay engaged in the side rails.

To Lower: Hold the crank handle in the same fashion as described above. Turn the crank handle in the opposite direction until shutter is closed, and turn no further. DO NOT FORCE.

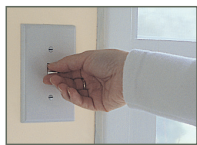

When operating motorized shutters: Ensure the shutter travel is clear of obstacles. Visually observe the shutter travel when operating the remote control or switch to ensure the curtain is not obstructed during operation. There are no reversing sensors on the shutter and damage may occur to the shutter or the obstacle. Obstructions can also throw off the upper or lower limit stops creating the need to reset them. Damages caused or repairs required due to shutter obstructions are not covered by warranty.



Locks: If you have slide locks, ensure the slide locks are completely drawn into curtain before operation. For cylinder locks, occasionally use a PTFE based dry film lubricant such as *Blaster* (found at Home Depot) or *CRC*, in keyway to keep debris clear and to lubricate lock tumblers.