



SPECIALTY STORE SERVICES

454 Jarvis Ave. Des Plaines, IL 60018
PH: (800) 999-0771 | FX: (888) 368-8001
www.specialtystoreservices.com

ASSEMBLY INSTRUCTIONS

#2113 4 Way Grid Spinner

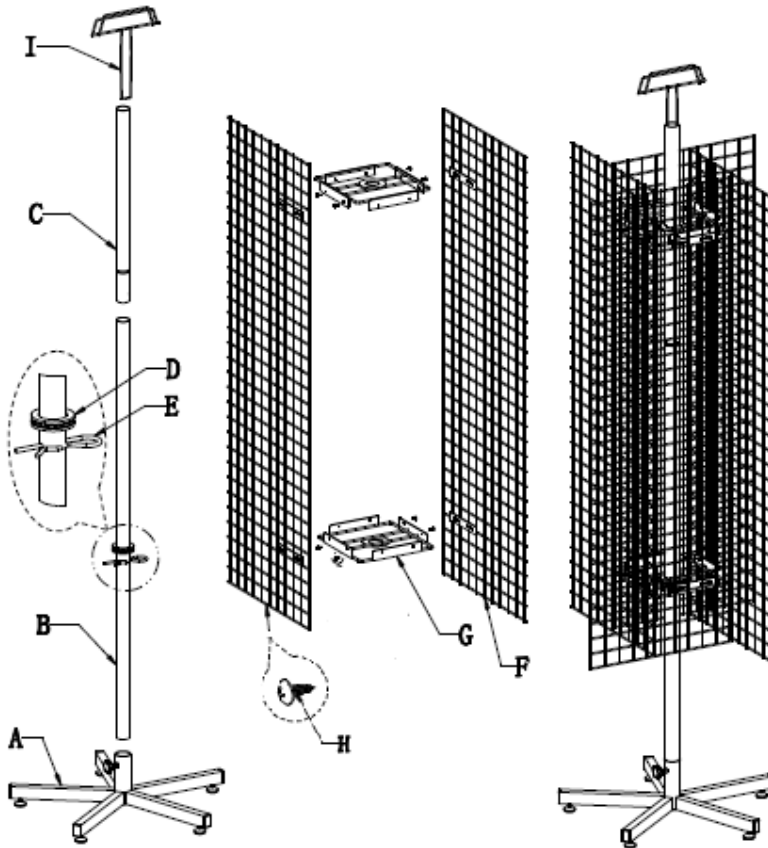

PARTS LIST

A- Base	1 pc
B- Lower pole	1 pc
C- Upper pole	1 pc
D- Bearing	1 set
E- Cotter Pin	1 pc
F- Grid net	4 pcs
G- Square frame	2 pcs
H- Screw	16 pcs
I- Sign Holder	1 pc

1. Insert Lower pole (B) into the Base (A) fixed by screw
2. Insert the Cotter Pin (E) through the Lower Pole (B)
3. Slide Bearing (D) down the Lower Pole (B)
4. Press the button on the Upper Pole (C) insert to Lower Pole (B) turn till the button pops out
5. Fix 4 Grids (F) to the 2 Square frames (G) with Screws (H) in turn (attention to the net direction)
6. Slide the assembled grid frame down the pole.
7. Insert the Sign Holder (I) onto the Upper Pole (C)

NEED MORE HELP? CALL 800-999-0771