

Assembly Instruction

1. Fix the Pole(B) to the Base(A) with Screw and Washer(C), tighten the bolt using the Wrench(D) provided.
2. Slide one Square Frame(E), one Bushing(F)(big side up), Spinner Lock(G)(big side up) down the Pole in turn.
3. Insert the Cotter pin(H) through the hole in the Pole(B), slide the Bearing(I), one Bushing(F)(big side down), one Square Frame(E) down the Pole in turn.
4. Hang the Wire Pocket Panels(J) onto the Square Frame(E) one by one. Make sure all the hooks are hooked onto the top and bottom square Frames.
5. Fasten the Spinner Lock(G) above the bottom Square Frame(E) to prevent the Square Frame(E) move up.
6. Insert the Sign Holder(K) into the top of the Pole(B).

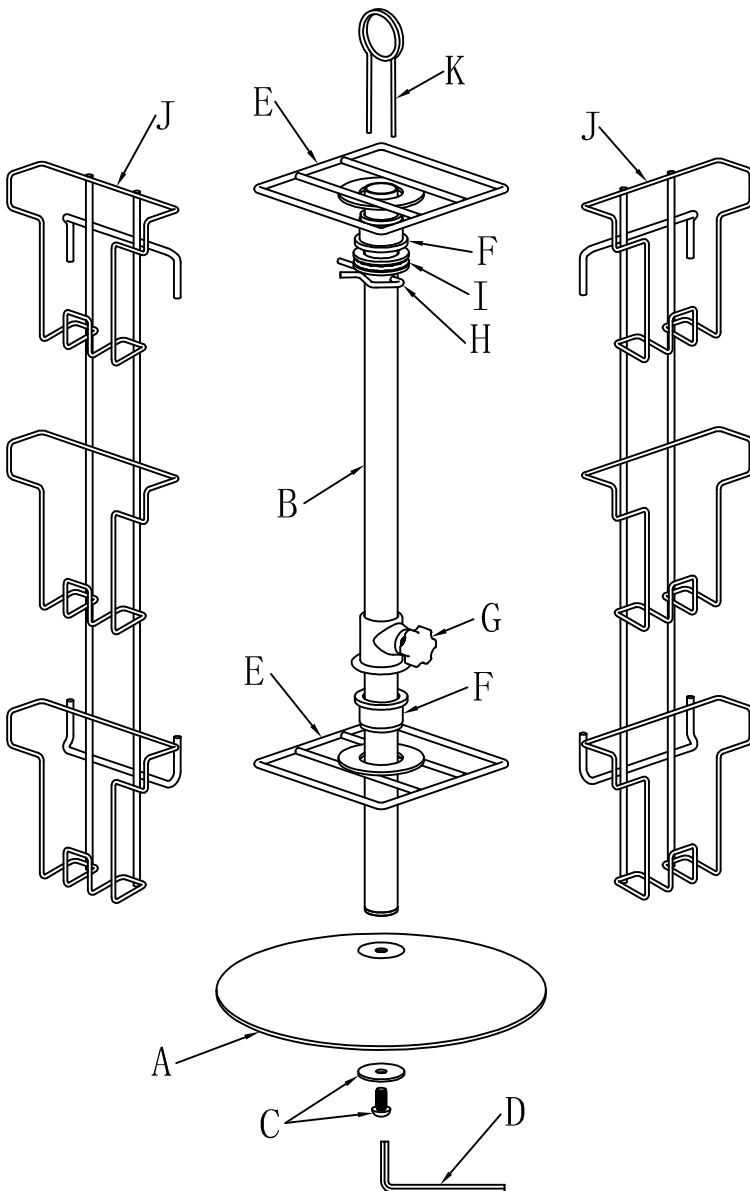

Part List:

A-Base	(1pc)
B-Pole	(1pc)
C-Bolt & Washer	(1set)
D-Wrench	(1pc)
E-Square Frame	(2pcs)
F-Bushing	(2pcs)
G-Spinner Locker	(1pc)
H-Cotter Pin	(1pc)
I-Bearing	(1pc)
J-Pocket Panel	(4pcs)
K-Sign Holder	(1pc)

Only For Assembly, Not As Drawing!