



SPECIALTY STORE SERVICES

454 Jarvis Ave. Des Plaines, IL 60018
PH: (800) 999-0771 | FX: (888) 368-8001
www.specialtystoreservices.com

ASSEMBLY INSTRUCTIONS

#2327 DOUBLE SIDE COUNTER SPINNER

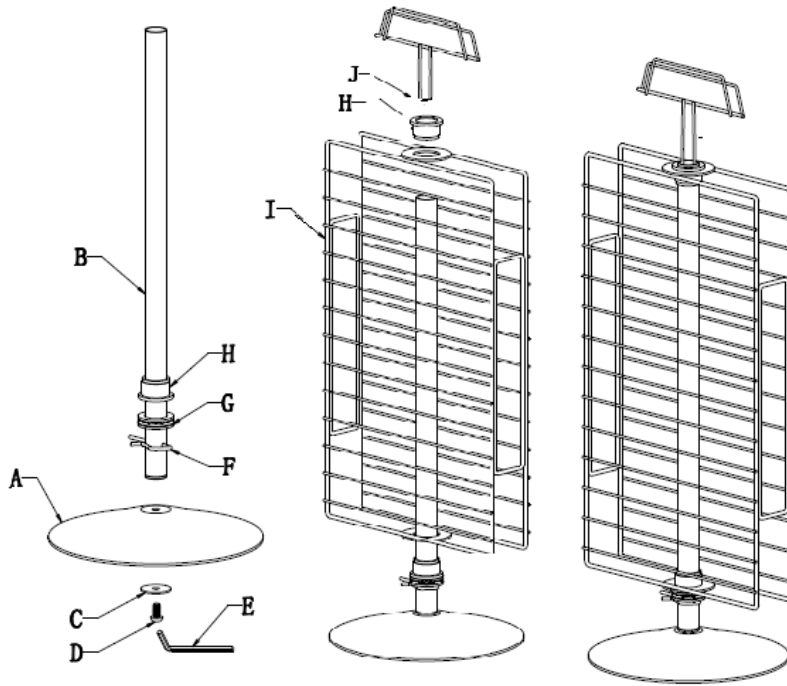

PARTS LIST

A- Base	1pc
B- Pole	1pc
C- Washer	1pc
D- Bolt	1pc
E- Wrench	1pc
F- Cotter Pin	1pc
G- Bearing	1pc
H- Bushing	2pc
I- Grid	1pcs
J- Sign Holder	1pc

1. Attach Pole (B) to Base (A) with Bolt (D) and Washer(C) tighten with Wrench
2. Insert Cotter Pin (F) into Pole (B)
3. Slide Bearing (G) and Busing (H) (small side up) into Pole (B)
4. Slide Grid (I) down Pole (B)
5. Slide another Busing (H) down Pole (B) (big side up)
6. Insert Sign Holder (J) into Pole (B)

NEED MORE HELP? CALL 800-999-0771